

**GENERAL NOTES:**

- 1) MAXIMUM FLOW RATE 50 G.P.M. (230 l/min)
- 2) INFLUENT TEMP.: 40° F (5° C) & GREATER
- 3) INFLUENT OIL SPECIFIC GRAVITY: < 0.95
- 4) EFFLUENT QUALITY: < 0.0016 oz/gal. (< 10mg/l) TEH
- 5) RECOMMENDED OIL STORAGE: 200 imp. gal. (910L)
- 6) SLUDGE CAPACITY: 12.75 cu. ft. (0.36 cu. m)
- 7) COALESCING MEDIUM: A.F.C. COALESCING PACKAGE
- 8) PIPING:  $\phi 4"$  (100)PVC

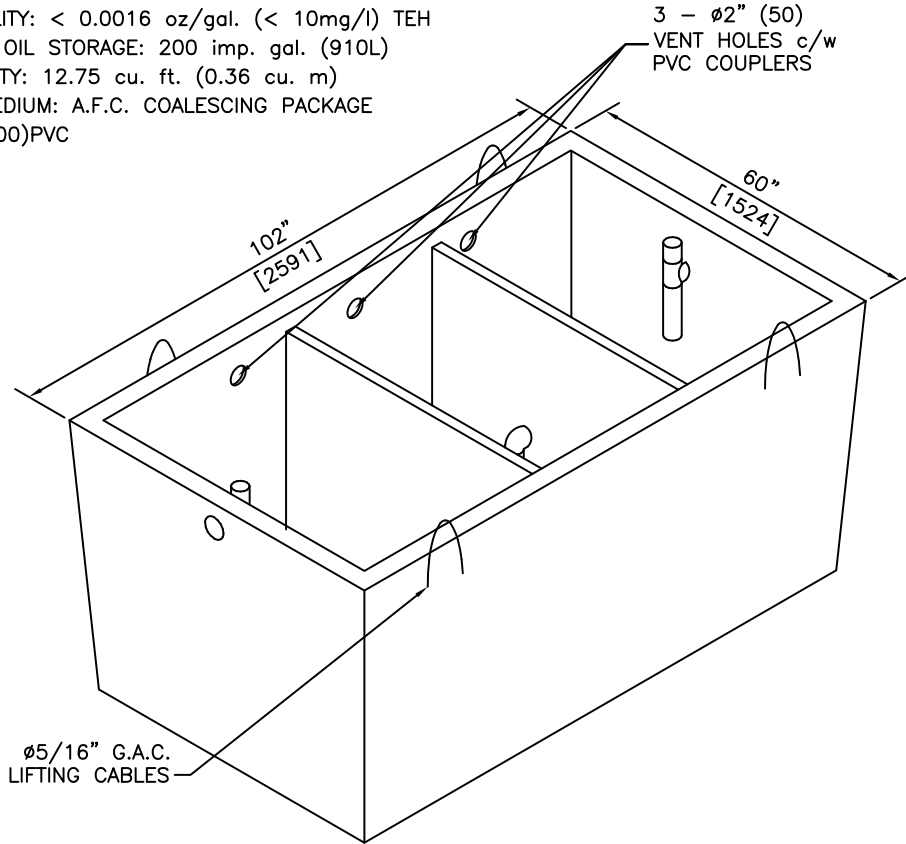

**ISOMETRIC**

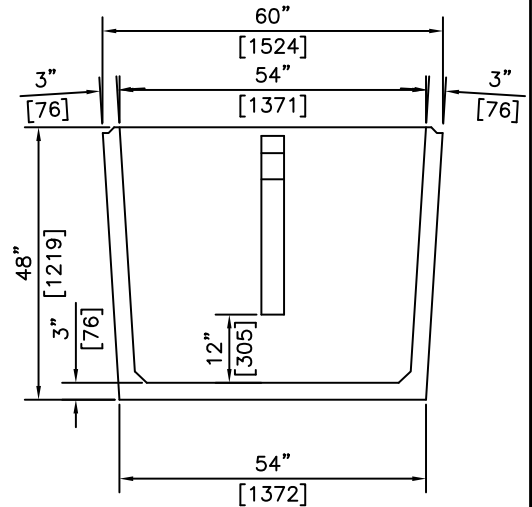
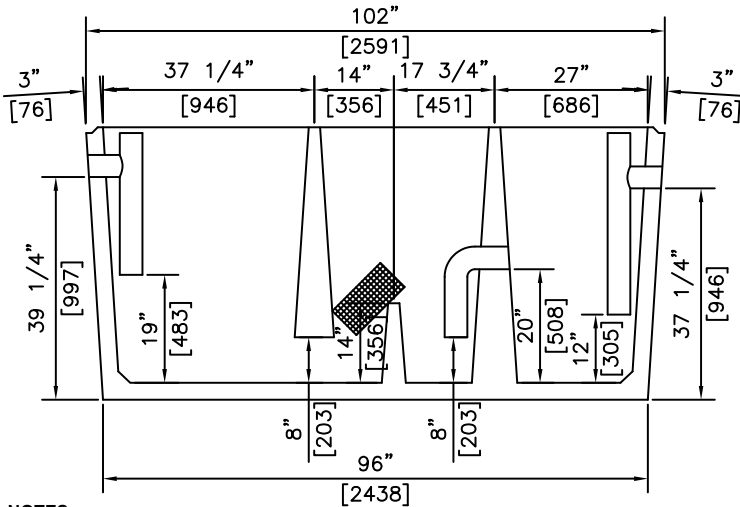

**SECTIONS**

**NOTES:**

US PATENT No 6,079,571  
CANADIAN PATENT No 2,252,307

AFC OIL/WATER SEPARATOR SPECIFICATIONS ARE SUBJECT TO LIMITATIONS OF LIABILITY

REVISED: MAR 31 2006

<p><b>A.F.C.</b> AMERICAN FORCECRETE OF CANADA Inc.</p>	<p>3891 Irvine Road LAKE COUNTRY, B.C. V4V 2G4 PH: (250) 548-0056 FX: (250) 765 0820</p>	<p>BY: PKR DATE: FEB 1 06 SCALE: NTS</p>	<p><b>AFC OIL/WATER SEPARATOR - 50GPM (230 LITRE)</b></p>	<p>ITEM NO. <b>1601</b></p>