

GENERAL NOTES:

- 1) MAXIMUM FLOW RATE 150 G.P.M. (680 l/min)
- 2) INFLUENT TEMP.: 40° F (5° C) & GREATER
- 3) INFLUENT OIL SPECIFIC GRAVITY: < 0.95
- 4) EFFLUENT QUALITY: < 0.0016 oz/gal. (< 10mg/l) TEH
- 5) RECOMMENDED OIL STORAGE: 117 imp. gal. (530L)
- 6) SLUDGE CAPACITY: 10.0 cu. ft. (0.28 cu. m)
- 7) COALESCING MEDIUM: A.F.C. COALESCING PACKAGE
- 8) PIPING: ϕ 6" (150) PVC

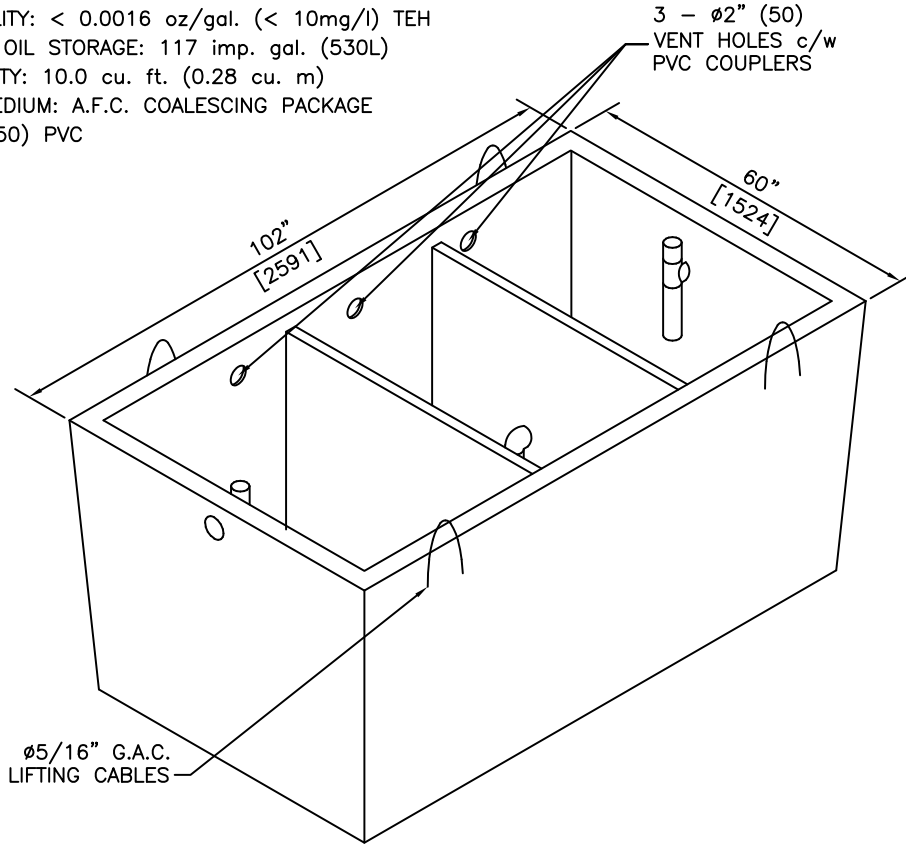

ISOMETRIC

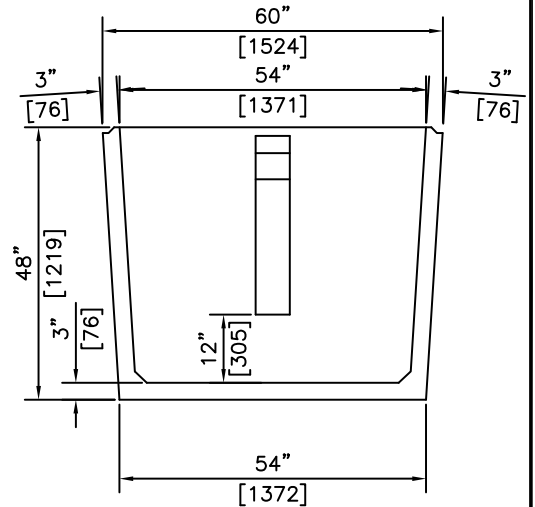
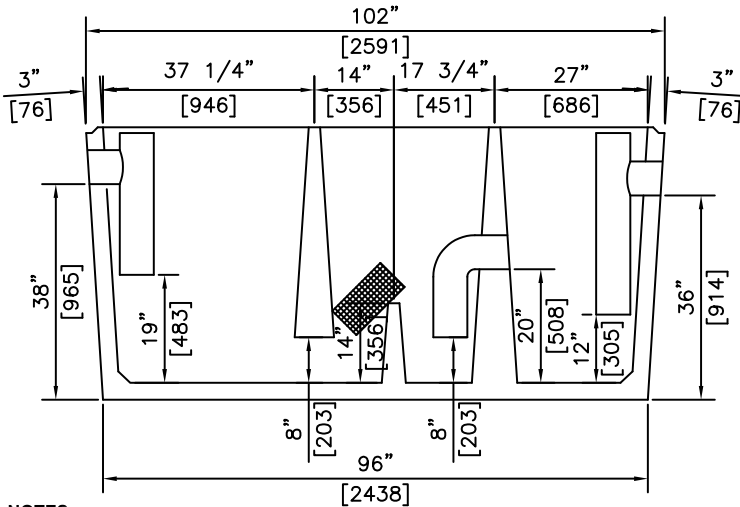

SECTIONS

NOTES:

US PATENT No 6,079,571
CANADIAN PATENT No 2,252,307

AFC OIL/WATER SEPARATOR SPECIFICATIONS ARE SUBJECT TO LIMITATIONS OF LIABILITY

REVISED: MAR 31 2006

<p>A.F.C. AMERICAN FORCECRETE OF CANADA Inc.</p>	3891 Irvine Road LAKE COUNTRY, B.C. V4V 2G4 PH: (250) 548-0056 FX: (250) 765 0820	BY: PKR	<p>AFC OIL/WATER SEPARATOR -150GPM (680L) H2O DESIGN</p>	ITEM NO.
		DATE: FEB 1 06		<p>1605E</p>
		SCALE: NTS		